

## PROJECT OF ROBOTIC CELL FOR HANDLING

Douglas Raphael Lima De Moraes<sup>1</sup>, [douglas.limamoraes@yahoo.com.br](mailto:douglas.limamoraes@yahoo.com.br)  
Erik Valter De Almeida<sup>1</sup>, [erikcdc@gmail.com](mailto:erikcdc@gmail.com)  
João Picanço Baltar<sup>1</sup>, [joaoguribaltar@gmail.com](mailto:joaoguribaltar@gmail.com)  
Maurício Hasmann Faria Alves<sup>1</sup>, [mauriciohfa@yahoo.com.br](mailto:mauriciohfa@yahoo.com.br)  
Keila Mota De Oliveira<sup>1</sup>, [keilamota14@gmail.com](mailto:keilamota14@gmail.com)  
Cleginaldo Pereira de Carvalho<sup>2</sup>, [cleginaldopcarvalho@hotmail.com](mailto:cleginaldopcarvalho@hotmail.com)

<sup>1</sup> Graduating in Mechanical Engineering, UNISAL –São Joaquim Campus.

<sup>2</sup> Doctor in Engineering, UNISAL –São Joaquim Campus.

<sup>1,2</sup> Afiliation: Unisal – Centro Universitário Salesiano de São Paulo

**Abstract** - This article has the purpose of developing an educational robotic cell through the automation by using the Arduino programming, demonstrating from the simplest to the most complex application. We will approach the main routines and their particularities. We will also discuss existing type of robot in today's world and which applies the best in this project.

**Keywords:** Arduino, Automation, Robotic, Programming, Handling.

### I. Introduction

The Arduino concept originated in Italy in 2005 with the objective of creating a device that is used in projects / prototypes built in a less expensive way than other systems available on the market.

The main idea is to encompass Arduino's hardware's concepts and free software and be available for usage and contribution to the whole society.

Arduino is a development kit that can be seen as a unit of processing capable of measuring external environment variable, transforming in a corresponding electric signal, through the wired sensors to its terminals. With these information, it can computationally process them. At last, it can still control or activate some other electronic element connected to its exit terminal.

In the programmable automation, the productive machinery is designed with the ability to modify the sequence so as to accommodate different product configurations operations. The sequence of operations is controlled by a program, a coded set of instrumentation so that it can be read and interpreted by

the system. Companies perform automation projects of production and computer integrated manufacturing for various reasons, some of them are as it follows: increase in productivity, reduction of labor costs, improvement in product quality, and reduction of production time.

Robots are powerful elements in the industry today, they are able to perform various tasks and operations, and they are accurate and do not require the security features and comfort that human's need. The topic robotics covers many different areas, they are usually integrated in a system as a whole, and it is designed to perform a task or an operation.

### II. Arduino Hardware

Until this moment, there are different version of Arduino, all based on a microprocessor of 8 bits Atmel AVR reduced instruction set computer (RISC). The first board was based on an ATmega8 running at a 16 MHz clock speed at 8 KB of flash memory; later plates such as Arduino NG plus and Diecimila (Italian for 10,000) used the ATmega168 with flash memory of 16 KB. The newer Arduino's versions, Duemilanove and Uno, use the ATmega328 with flash memory of 32 KB and can automatically compute between USB and direct current (DC). For projects that require more I / O and memory, there is the Arduino Mega1280, with 128 KB of memory, or the latest Arduino Mega2560, with 256 KB of memory. The plates have 14 digital pins, and each can be defined as input or output, and six analog inputs. Additionally, six of the digital pins can be programmed to provide a pulse-width modulation output (PWM). Several communication protocols are available, including serial, serial peripheral interface (SPI) and I2C / TWI; included on each plate as a

standard feature is a serial programming in-circuit connector (ICSP) and a reset button. [1]

A. *Arduino Mega (utilized in this project).*

The Arduino family elder brother, Mega, uses a larger mounting surface microprocessor. The ATmega1280, the Mega, has been updated the same time as the Uno, and the microprocessor used is now the ATmega2560. The new version has 256 KB of flash memory, up from the original 128 KB. Mega provides a significant increase in input-output functionality over standard Arduino; therefore, with the increase of memory, it is ideal for those larger designs which control great amounts of LEDs, has a large number of inputs and outputs, and requires more than one serial port hardware – the Arduino Mega has four. The plates have 54 digital input-output pins, 14 of which can provide analog output PWM, and 16 analog input pins. Communication is done with up to four serial ports hardware. The SPI communication and support for I2C / TWI devices are also available. The board also includes an ICSP connector and a reset button. An ATmega8U2 replaces the FTDI chipset used by his predecessor and processes the USB serial communication. Mega operates with the most available doss shields, but it's a good idea to check if a shield will be compatible with your Mega before you buy it. Buy the Mega when you really need to use additional pin input-output and need larger memory capacity. See the following picture: [2]

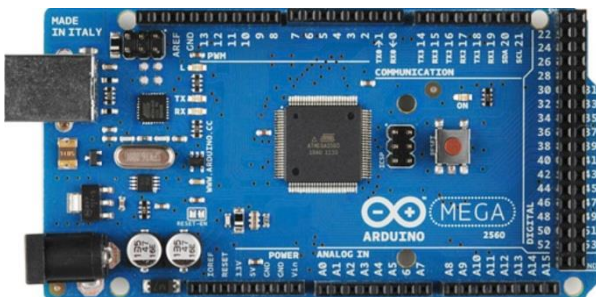

Figure 1: Arduino Mega

Source:[https://www.robotics.org.za/index.php?route=product/product&product\\_id=80](https://www.robotics.org.za/index.php?route=product/product&product_id=80)

**III. Automation**

In an industrial context, automation can be defined as the technology that deals with the use of mechanical systems, electronics and computer operation and control of production. Several examples of automation production systems can be seen in industrial production lines, the mechanized assembly machines, fed back in industrial production control systems in machine tools equipped with numerical controls and robots for industrial use. [4]

Some of the most common reasons to justify the automation are as follows:

- Increase productivity;

- Reduce work costs;
- Minimize de effects of lack of workers;
- Improve product quality;
- Minimize production time;
- Execute jobs that can't be executed manually.

B. *Automation x Mechanization*

Automation is different from mechanization. Mechanization simply consists of using machines to perform a job, replacing the physical effort of man. Automation makes it possible to work through automatically controlled machines, able of self-regulation. [4]

**IV. Automation Advantages and Disadvantages**

Industrial automation is one way many companies found to improve the process of producing their products. One of the advantages of using industrial automation is the fact that the machines, allied to technological advances and the Internet, can do better and faster a man's job. Another advantage of industrial automation is the capital, a machine costs too high and the owner of the company will bear the value of maintenance of the appliance. However, if he hired people to do the work of the machine, the owner would have to pay for health insurance, leave, holidays and various other benefits that the employee is entitled under the law.

The major disadvantages of automation are the cost if and when a machine break, the cost to fix it can be extremely high. In addition, the number of professionals who know how to work with the industrial automation is very small in Brazil. The training course for those who want to work with these machines has not yet formed many professionals. Another disadvantage of industrial automation is increasing social inequality. Many people lose their jobs and are replaced by these machines. This makes these people, if they fail a new job, end up marginalized. These are some of the advantages and disadvantages of automation. [4]

**V. Robotic**

Robotics is the application and use of robots in human activity. Robotic systems consist not only in the use of robots, but also in other devices and systems used in conjunction with robots. Robotics is the application and use of robots in human activity. Robotic systems consist not only in the use of robots, but also in other devices and systems used in conjunction with robots.

## VI. Robots Classifications

According to the Japanese Industrial Robot Association (JIRA), the robots are classified as follows:

**Class 1** – *Drive device Manual: device with multiple degrees of freedom driven by an operator.*

**Class 2** – *Fixed sequence robot, a device that performs successive steps of a task according to a certain method that cannot be changed.*

**Class 3** – *Variable Sequence robot, a device that performs successive steps of a task according to a certain method that allows alterations.*

**Class 4** – *Playback Robot: a human operator performs the task manually, taking the robot, which records the movements. The robot will repeat the same movements according to the recorded information.*

**Class 5** – *Numerical Control Robot: the operator gives the robot a motion program without the need to perform manually for recording.*

**Class 6** – *Intelligent Robot: A robot capable of interpreting their environment and successfully complete a task, even under changes in environmental conditions. [3]*

## VII. Robot control systems

The activations of individual joints need to be controlled in a coordinated manner to be held the cycle of desired movements. Different types of control are needed for different applications. They are classified into four categories..

**Cat. 1** – *Limited sequence control: this is the most basic control type, used for simple motion cycles, for example, pick up an object in one place and put on another. It sets limits or mechanical stops for each joint to complete the cycle.*

**Cat. 2** – *Control peer: More sophisticated programmable controls compared to limited sequence robots. The controller contains a memory for recording the sequence of movements of a particular cycle, in addition to position and velocity associated with each movement. These positions are not limited and consist of a set of values representing locations in range of each handler. Thus each "point" consists of five or six values corresponding to the positions of each joint.*

**Cat. 3** – *Continuous path control: Robots with continuous path control have the same capacity for executing the type "point to point", however, are capable of greater storage capacity of the number of locations that can be registered in memory. Thus, they constitute the movement cycle can be spaced and allow for a smoother movement. And capable of performing interpolation calculations, i.e., the controller calculates the route between the starting point and ending point of each movement routines using linear interpolation and circular.*

**Cat. 4** – *Intelligent Control: displays a behavior which does have intelligent features, for example, interacts with the environment, makes decisions when they detect an error during the work cycle, communicates with people, performs calculations and reacts to incoming sensory data with machine vision. [3]*

## VIII. Sensors in Robotics

The sensors used in robotics are classified in two categories:

**Cat. 1** – *Internal Sensors: used to control the positions and velocities of the joints. Sensors to control robot arm's position are potentiometers and encoders and tachometers are used to control the speed of the robot arm.*

**Cat. 2** – *External Sensors: used to coordinate the robot operation with other equipment. These are devices such as limit switches that determine whether a piece was positioned properly on a template or if the piece is ready to be picked up and transported. There are other situations that require more advanced sensor technologies, for instance, tactile sensors, proximity, optical, machine vision, etc.*

## IX. Robot's Components

A robot as a system consists of the following elements to develop:

**Manipulator:** This is the main body of the robot, which consists in the connection of joints and other structural elements of the robot.

**Final Actuator:** It is the part connecting the last joint (hand) of the manipulator that, in general, manipulates objects.

**Actuators:** They are the "muscles" of the handlers. The controller sends the command to the actuators, which move the joints and robot links. The types of actuators are Servo motors, stepper motor, pneumatic actuators and hydraulic actuators.

**Sensors:** The sensors are used to collect internal data of the robot or communicate with the external environment. The robot needs to know the location of each link to understand your configuration and execute it.

**Controller:** Receives data from the computer (brain system), controls movement of the actuators and coordinates movements with sensory feedback information.

**Processor:** It is the brain of the robot. Its function is to compute your desired speed and oversees the controller coordinated actions and sensors. The processor is typically a computer.

**Software:** It contains three groups of programs used in a robot. Operating system that runs the processor; robotic software that calculates movement of each joint

and the last group is a set of routines oriented applications and programs developed for use by the robot or its peripherals for specific tasks such as assembly, machine loading, material handling. [3]

**X. Robot’s Characteristics**

Robots are characterized according to its settings.

**Payload:** is the weight a robot can carry and still remain its other specifications such as: the need to keep their trajectory in its movements and have no excessive gaps.

**Reach:** is the maximum distance that a robot can reach within its working space.

**Precision:** Is defined as how close you can get to a given point in range. This is a function of the actuators and sensors that are needed to perform its load with position and speed of movement.

**Repetition:** Is the precision with which the robot can execute its movements in the same position and speed repeating several times.

**XI. Materials and Methods**

In order to meet the needs of the discipline, we decided that the robot used will be a robot according to Class 3, so a variable sequence robot and category 2, namely, control point to point.

For the development of programming we are using a method of allocation of commands by the control board, where each component responsible for the movement, record and arm drive sends a signal and it is stored in the programming code.

We adopted this method because it is an intuitive way of programming, meaning, to determine the routines to be executed by the robot it is not necessary the use of a computer, unless, a change in the programming is needed.

For the robot’s programming we use the Arduino Mega, mainly due to the great cost-benefit, because it is an Arduino microprocessor with a good processing fee and also for having a large number of analog inputs, digital and PWN.

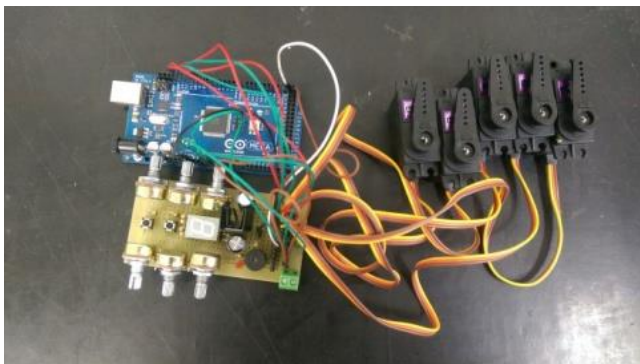

Figure 2 – Arduino Module, Control Board and Servo motors

The arm will be able to make up to 09 different pre-determined routines, and as the main routine performing the movement of a block from a position A to a position B, the drive will be done by an infrared sensor that as it detects the block sends the command to the arm for conducting the selected routine.

Below we can verify the concept and the draft of the developing robot.



Figura 3 – Robot Layout/Concept

Robotic Arm - Features		
Total Haste Length	cm	55
Maximum Reach in Y	cm	55
Maximum Reach in X	cm	50
Maximum Reach in Z	cm	50
Power	N.m	11

Table 1. Robotic Arm Features

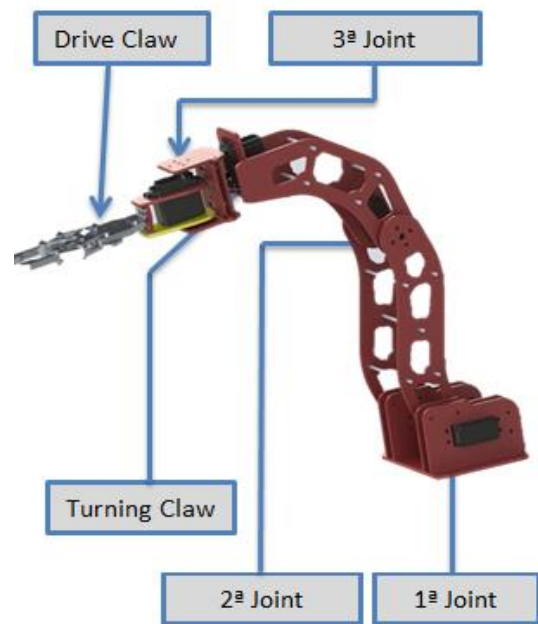
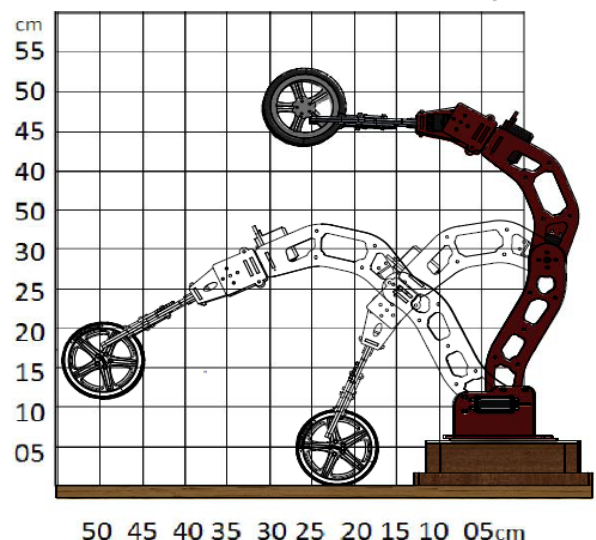

4	Infrared Sensor		1	6,00
5	Acylic Board	Reused	1	0,00
6	Spacers Pins	Reused	9	0,00
7	Aluminum Board	Reused	1	0,00
8	Bolts and Nuts	Ciser	15	0,00
				<b>TOTAL</b>
				<b>R\$ 215,85</b>

Table 2. List of Materials

The other characteristics of the robot such as payload, range, accuracy and repeatability are determined empirically during the performance of the robot tests.

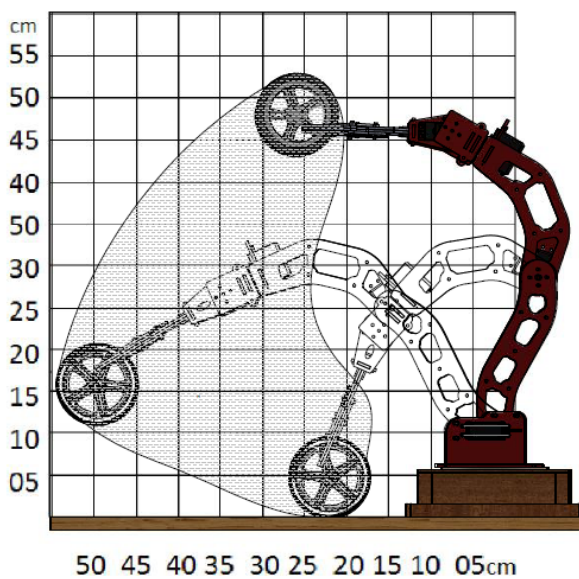

Figure 6. Robot Layout/Concept - SOLIDWORKS Educational License (educational use only).

Below we can verify the list of materials that will be used for the production and the estimated cost of the items.

List of Materials				
Item	Component		Quant.	Price R\$
1	Servo motor MG996R	Tower Pro	7	122,85
2	Arduino Mega	Arduino	1	67,00
3	Interface Board	Own	1	20,00

## XII. Conclusion

In the course of the stages of this project, it has been possible to consolidate the knowledge about robotics and automation and the importance of these tools in the industry as well as its analysis of economic technical feasibility, in other words, just when you really do need investment and what productivity gains and quality you will get. Such a comparison can be performed by raising operating costs or the actual value stream mapping of the production process, being a tool which shows in a very clear and objective way if we are carrying out unnecessary steps in the development of the production process.

## Bibliography

- [1]. MARTIN EVANS, JOSHUA NOBLE e JORDAN HOCHENBAUM. **Arduino em ação**. 1º ed. Tradução e Rev. Rubens Prates, Camila Paduan, Rodrigo Stulzer, Marta Almeida de Sá Carolina Kuwabata, São Paulo, SP copyright 2013 pela Novatec Editora Ltda.2013.
- [2]. MICHAEL McROBERTS. **Arduino básico**. 1º ed. Tradução e Rev. Rubens Prates, Camila Kuwabata, Rodrigo Stulzer, Marta Almeida de Sá Carolina Kuwabata, Rafael Zanolli, Edgard Damiani. São Paulo, SP copyright 2013 pela Novatec Editora Ltda.2011.
- [3]. SAEED B. NIKU. **Introdução à Robótica: Análise, Controle, Aplicações**. 2º ed. Tradução e

Rev. Técnica. Sérgio Gilberto Taboada. Rio de Janeiro, RJ: LTC, 2014.

- [4]. GROOVER MIKELL P. **Automação Industrial e Sistemas de Manufatura**. 3º ed. Tradução. Jorge Ritter, Luciana do Amaral Teixeira e Marcos Vieira. Rev. Técnica. José Hamilton Chaves Gorgulho Júnior. São Paulo, SP: Pearson Prentice Hall, 2011.
- [5]. CÍCERO COUTODE MORAES. PLÍNIO DE LAURO CASTRUCCI. **Engenharia de Automação industrial**. Hardware e Software, Redes de Petri Gestão da Automação. 2º ed. Rio de Janeiro: LTC, 2013.
- [6]. JOSÉ LUIZ LOUREIRO ALVES. **Instrumentação, Controle e Automação de Processos**. 2º ed. Rio de Janeiro: LCT, 2013.
- [8]. NABAIS, R. **Material de aula da disciplina Controle Automático de Processos**. Coimbra: Instituto Politécnico – Curso de Engenharia Alimentar. Coimbra/Portugal. Disponível em: <[www.esac.pt/rnabais/InstEquip/.../Sensores\\_nivel.pdf](http://www.esac.pt/rnabais/InstEquip/.../Sensores_nivel.pdf)>. Acesso em: out. de 2009.
- [9]. AQUINO, P. L. S. Material de aula da disciplina **Instrumentação Eletrônica**: Curso de Engenharia Industrial Elétrica. Rio de Janeiro: CEFET.
- [10]. NATALE, F. **Automação Industrial**: Série Brasileira de Tecnologia. São Paulo: Editora Érica, 2000.
- [11]. FIALHO, A. B. **Instrumentação Industrial**: Conceitos, Aplicações e Análises. 4.ed. São Paulo: Editora Érica, 2002.